

LabelNest™

# E-Display LN21™

Product Code: FC- FAC16

FootfallCam Product

E-display



## Key Features

- ▶ Advanced Battery Saving Chipset Only Available in Texas Instrument; Low Consumption
- ▶ Fully graphic and Available in up to Three Colours
- ▶ Wireless 2-way Communication Between Your System and The Display
- ▶ Multi-language Enabled, Able to Show Complex Information
- ▶ Customizable Layout and Content
- ▶ LED Flashing for Geolocation
- ▶ Support by Multiple Fitting Options- Table Top with Adapter, Rails, Rail Remover Kits
- ▶ Easy to Install, Integrate and Maintain

**LabelNest LN21™** is a 2.1-inch electronic display device that can be placed on the shelf and replaced the traditional paper price label. The E-paper display technology boasts a high contrast ratio, makes superior viewing angle at nearly 180°. Each device is connected to the FootfallCam 3D Max2™ base station through wireless network. The changes or configuration of the price on the product can be adjusted via LabelNest Analytic Manager software and transmitted to the base station and to the label. The latest content can then be updated on the screen in real time basis with a more efficient way.



# LabelNest LN21™

## GENERAL SPECIFICATION

Model	ESL LN21
Screen Size	2.1 inch (Diagonal)
Weight	30g (Approx.)
Appearance	White casing (By Default)
Chipset	Texas Instrument CC1310
Material	ABS (Acrylonitrile Butadiene Styrene)
Total Dimension	67mm x 34mm x 13mm

## OPERATION

Operating Temperature	0-50°C
Battery Life Time	3- 5 years (Subjective to usage)
Battery	2 x CR2450 (Replaceable batteries)
Power	100mW

## DISPLAY

Display Area	49mm x 24mm
Display Colour	Black & White, Red & White, Yellow & White
Display Mode	Dot Matrix Display
Resolution	212 (H) x 104 (W)
Pixel Pitch	0.229mm x 104mm
Reflect Contrast	7:1
Whiteness Reflect	33 %
Viewing Angle	175°
Time of Refresh	16 s
Power Consumption of Refresh	8 mA
Language	Multi-Language Available
Bar Code/ QR Code on Screen	Yes

## FRONT VIEW

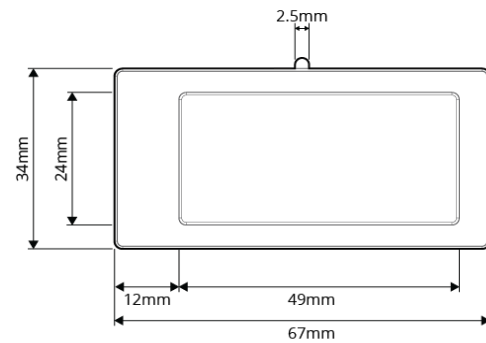

## TOP VIEW

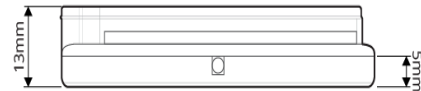

## SIDE VIEW

